

TECHNICAL BULLETIN

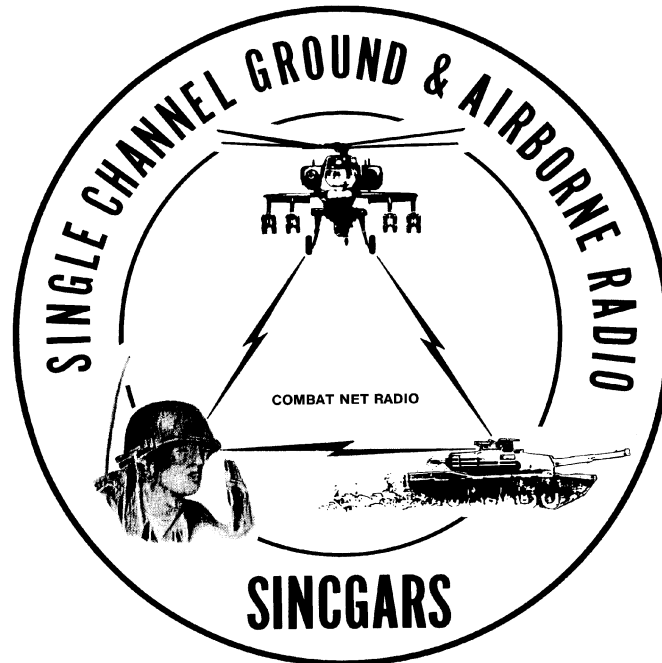

**INSTALLATION INSTRUCTIONS FOR
INSTALLATION KIT,
ELECTRONIC EQUIPMENT, MK-2333/VRC
(NSN 5895-01-309-4600) (EIC: N/A)
TO PERMIT INSTALLATION OF RADIO SETS
AN/VRC-89/91/92 SERIES
IN A
BASE STATION, DUAL**

Approved for public release; distribution is unlimited.

HEADQUARTERS, DEPARTMENT OF THE ARMY

1 AUGUST 1999

**INSTALLATION INSTRUCTIONS FOR
INSTALLATION KIT
ELECTRONIC EQUIPMENT MK-2333/VRC
(NSN 5895-01-309-4600) (EIC: N/A)
TO PERMIT INSTALLATION OF RADIO SETS
AN/VRC-89/91/92 SERIES
IN A
BASE STATION, DUAL**

REPORTING OF ERRORS AND RECOMMENDING IMPROVEMENTS

You can help improve this manual. If you find any mistakes or if you know of a way to improve the procedures, please let us know. Mail your letter, DA Form 2028 (Recommended Changes to Publications and Blank Forms), or DA Form 2028-2 located in the back of this manual direct to: Commander, US Army Communications-Electronics Command Fort Monmouth, ATTN: AMSEL-LC-LEO-D-CS-CFO, Fort Monmouth, NJ 07703-5000. The Fax number is 732-532-1413, DSN 992-1413. You may also e-mail your recommendation to AMSEL-LC-LEO-PUBS-CHG@cecom3.monmouth.army.mil.

In either case, a reply will be furnished direct to you.

TABLE OF CONTENTS

Subject	Section	Page
Scope	0.1	1
General Information	0.2	1
Maintenance Forms, Records, and Reports	0.3	1
Reports of Maintenance and Unsatisfactory Equipment.....	0.3.1	1
Report of Packing and Handling Deficiencies	0.3.2	1
Discrepancy in Transportation Deficiency Report (TDR) (SF 361).....	0.3.3	1
Consolidated Index of Army Publications	0.4	1
Purpose of Installation.....	1.	2
End Item or System to be Modified	2.	2
Application Times.....	3.	2
Time for Completion of Installation	3.1	2
Time for Installation of One Assembly or Component	3.2	2
Preparation for Installation	4.	2
Preparation of Vehicle.....	4.1	2
Preparation of MK	4.2	2
MK, Distribution, and Consumables	4.3	3
Tools and Test, Measurement, and Diagnostic Equipment (TMDE) Required	4.4	7
Installation Procedures.....	5.	8
Installation of Mounting Base, Electrical Equipment MT-6352/VRC (mounting base).....	5.1	10
Installation of Loudspeaker, Control Unit, LS-671/VRC	5.2	14

*This manual supersedes TB 11-5820-890-20-2, 1 September 1993

Installation of Cables.....	5.3	13
Installation of Mounting Base, Electrical Equipment MT-6353/VRC.....	5.4	14
Post-Installation and Checkout.....	5.5	16
Appendix A References.....		A-1

LIST OF ILLUSTRATIONS

Figure	Title	Page
4-1	MK Illustrated Parts List.....	5
4-2	Illustrated Parts List for Table 4-2.....	6
5-1(1)	MK and Radio Installation: MK Equipment Locations (Typical).....	8
5-1(2)	MK and Radio Installation: Radio Equipment Locations (Typical).....	9
5-2	Mounting Base Installation.....	11
5-3	Speaker Installation.....	13
5-4	Cable Installation: Rack, Typical.....	15
5-5	MT-6353/VRC Mounting Base Installation.....	17
5-6	Cable Diagram: For AN/VRC-89/91/92 Series.....	19

LIST OF TABLES

Table	Title	Page
4-1	Parts List for Installation of Radio Set AN/VRC-89/91/92 Series.....	4
4-2	Additional Items Required for Installation of Radio Set AN/VRC-92 Series.....	6

0.1 SCOPE.

This technical bulletin provides installation instructions for Installation Kit, Electronic Equipment MK-2333/VRC, commonly referred to as the Mounting Kit (MK). The MK shall be installed into the following:

- Base Station, Dual

The MK is used for installation of radio set components at field locations. The information contained in this technical bulletin is the official authorization to perform the installation at the unit maintenance level.

NOTES

- This technical bulletin is not an authorization for requisition or turn-in of vehicles.
- This technical bulletin does not establish quantity or types of vehicles assigned to using units.

This technical bulletin does not contain information on the maintenance or replacement of the MKs. This information is contained in the MAC of TM 11-5820-890-20-2, TM 11-5820-890-20-4 and RPSTL of TM 11-5820-890-20P.

0.2 GENERAL INFORMATION.

The MK becomes operable when all the radio set components are installed in the vehicle and correct power is supplied. Refer to TM 11-5820-890-20-1 or TM 11-5820-890-20-4 for installation, Operational (OP) Check instructions, and required maintenance procedures. Refer to TM 11-5820-890-20P for repair parts.

Included in the radio set AN/VRC-89/91/92 Series is:

- Radio Set AN/VRC-89/91/92 Series (for RT-1523(C)/U)

0.3 MAINTENANCE FORMS, RECORDS, AND REPORTS.

0.3.1 Reports of Maintenance and Unsatisfactory Equipment. See Section 4.2.2.3 for information.

0.3.2 Report of Packing and Handling Deficiencies. See Section 4.2.2.1 for information.

0.3.3 Discrepancy in Transportation Deficiency Report (TDR) (SF361). See Section 4.2.2.2 for information.

0.4 CONSOLIDATED INDEX OF ARMY PUBLICATIONS.

Refer to the latest issue of DA Pam 25-30 to determine whether there are new changes, or additional publications pertaining to the equipment.

1. PURPOSE OF INSTALLATION.

The Installation Kit Electronic Equipment MK-2333/VRC (MK) contains the items needed to mount Radio Set AN/VRC-89/91/92 Series in a Base Station, Dual. If Radio Set AN/VRC-92 Series is authorized, see Section 5.4 for instructions to install MT-6353/VRC mounting base.

2. END ITEM OR SYSTEM TO BE MODIFIED.

Not applicable.

3. APPLICATION TIMES.

3.1 Time for Completion of Installation. Using two people, a total of 3.5 work hours is required. Typical station downtime is 4.0 hours.

3.2 Time for Installation of One Assembly or Component. The following table lists the time required to install one component. All times have been rounded off to the nearest half hour. The sum of these items will not reflect the typical vehicle downtime.

ITEM	SECTION	TIME
Mounting Base, Electrical Equipment MT-6352/VRC	5.1	1.5
Loudspeaker, Control Unit LS-671/VRC	5.2	0.5
Cables	5.3	1.0

4. PREPARATION FOR INSTALLATION.

This section explains how to prepare the vehicle and MK for installation.

4.1 Preparation of Vehicle. To prepare the vehicle for installation, insure that the site includes adequate lighting and a power source when drilling is required. Inspect the vehicle for damage that could affect installation. Have any such damage repaired before installing MK.

4.1.1 Items to be Removed. Remove existing AN/VRC-12 radio family installation kit/harness. See TM 11-5820-401-20-2 for removing items used with intercom systems, or TM 11-5820-401-20-1 (used without intercom systems), and TM 9-2320-289-20.

4.1.2 Items to be Retained. Not applicable.

4.2 Preparation of MK. To prepare MK, unpack, inspect and check inventory.

4.2.1 Precautions During Handling. Observe these steps to prevent equipment damage.

- a. Keep dust cover in place on connectors.
- b. Do not disassemble or modify parts in MK unless authorized to do so.
- c. Keep mounting hardware covered and protected until needed.
- d. When exposed to moisture, rain or salt water, keep all parts dry to prevent corrosion.

4.2.2 Unpack and Inspect Equipment.

4.2.2.1 Inspect Packaging for Evidence of Damage. Any shipping damage should be reported on SF364 Report of Discrepancy (ROD) as prescribed in AR 735-11-2/DLAR 4140.55/NAVMATINST 4355.73A/AFR 400-64/MCO 4430.3F.

4.2.2.2 Unpack and Inventory MK. If any item is missing, fill out and forward Transportation Deficiency Report (TDR) (SF361) as described in AR 55-38/NAVSUPINST 4610.33C/AFR 75-18/MCO P4610.19D/DLAR 4500.15.

4.2.2.3 Examine Each Item for Damage. If any item is damaged, fill out and forward SF364 Report of Discrepancy (ROD) as prescribed in AR 735-11-2/DLAR 4140.55/NAVMATINST 4355.73A/AFR-400-64/MCO 4430.3F. All damages should be reported as prescribed in DA Pam 738-750, as contained in Maintenance Management Update.

4.3 MK, Distribution and Consumables.

4.3.1 Items Supplied in MK and/or Required for Installation. Use Table 4-1 and Figure 4-1 to identify and inventory MK parts supplied to install Radio Set AN/VRC-89/91/92 Series. Refer to Table 4-2 and Figure 4-2 to identify additional items required to install Radio Set AN/VRC-92 Series.

4.3.2 Distribution and Issue Instructions.

- a. US Forces: Do not requisition MK. They will be shipped automatically.
- b. US Army Depots: Requisition MK through supply channels.
- c. Multiservice: Instructions shall be included for multiservice modifications.
- d. MAP/MAS Countries: Instructions shall be provided for MAP/MAS countries.

Table 4.1. Parts List for Installation of Radio Set AN/VRC-89/91/92 Series

NSN	ITEM DESCRIPTION AND PART NUMBER	QUANTITY IN MK	SMR CODE	FIGURE, ITEM NO.
5975-01-188-8873	Mounting Base, Electrical Equipment MT-6352/VRC(A3013367-1)	1	PAOOF A	4-1, 1
5306-00-225-9089	Bolt, Machine (5/16-24 x 1 in) MS90726-34	5	PAOZZA	
5310-00-889-2527	Washer, Lock, Internal/External-Toothed (5/16 in) MS45904-72	10	PAOZZA	
5310-00-880-7746	Nut, Hexagon (5/16-24 in) MS51968-5	5	PAOZZA	
5995-01-219-1843	Cable Assembly, Power, Electrical CX-13302/VRC (13 FT, 0 in) (A3014039-2)	1	PAOZZA	4-1, 2
5995-01-219-4704	Cable Assembly, Special Purpose, Electrical CX-13292/VRC (6FT, 0 in) (A3014038-3)	2	PAOZZA	4-1, 3
5965-00-222-1420	Loudspeaker, Control Unit LS-671/VRC (A3014065-1)	2	PAOOF A	4-1, 5
5965-00-043-3463	Handset, H-250/U	2	PAOZZA	4-1, 4
	Plate, Mounting (A3014550-1)	2	XBOZZA	4-1, 6
	Lead, Electrical (5 FT, 0 in) A3013552-8	1	PAOZZA	
5306-00-225-9093	Bolt, Machine (5/16-24 x 1 1/2 in) MS90726-38	13	PAOZZA	
5310-00-407-9566	Nut, Hexagon (5/16-24 in) MS51968-5	4	PAOZZA	
5310-00-081-4219	Washer, Flat (5/16 in) MS27183-12	13	PAOZZA	
5310-00-407-9566	Washer, Lock (5/16 in) MS35338-45	4	PAOZZA	
5975-00-111-3208	Strap, Tiedown, Electrical Components MS3367-5-9	5	PAOZZA	

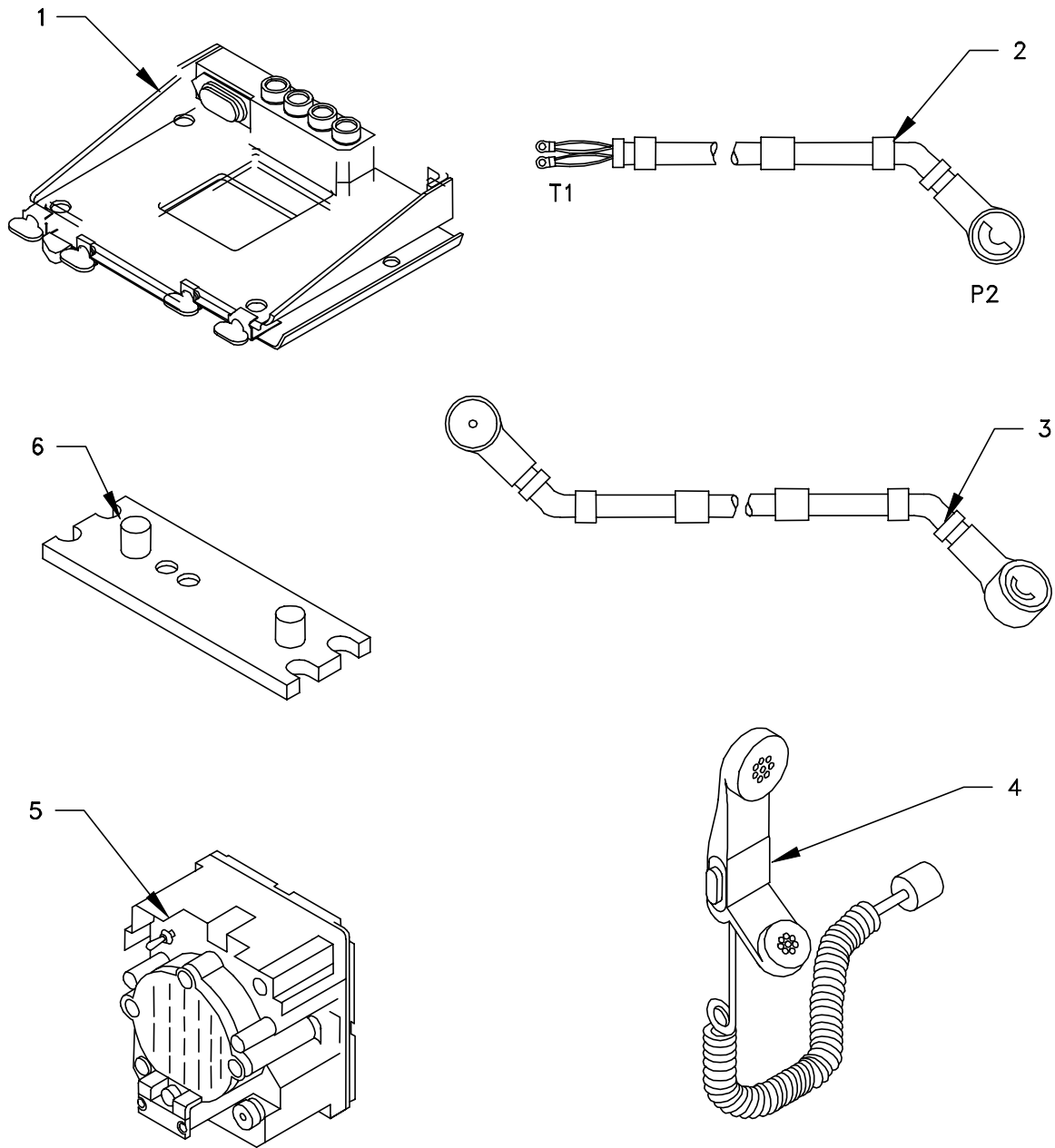

Figure 4-1. MK Illustrated Parts List

Table 4.2. Additional Items Required for Installation of Radio Set AN/VRC-92 Series

NSN	ITEM DESCRIPTION AND PART NUMBER	QUANTITY IN MK	SMR CODE	FIGURE, ITEM NO.
5975-01-235-1962	Mounting Base, Electrical Equipment MT-6353/VRC (A3014053-1)	1	PAOOHA	4-2, 1
5306-00-225-9089	Bolt, Machine (5/16-24 x 1 in) MS90726-34	4	PAOZZA	
5310-00-880-7746	Nut, Hexagon (5/16-24 in) MS51968-5	2	PAOZZA	
5310-00-889-2527	Washer, Lock, Internal/External-Toothed (5/16 in) MS45904-72	6	PAOZZA	
5310-00-081-4219	Washer, Flat (5/16 in) MS27183-12	2	PAOZZA	
5975-00-111-3208	Nut Strip (A3014064-1)	1	XBOZZA	4-2, 5
5975-00-111-3208	Strap, Tiedown, Electrical Components MS3367-5-9	4	PAOZZA	
5995-01-300-9324	Cable Assembly, Power, Electrical CX-13303/VRC (4 FT, 6 IN) (A3014040-9)	1	PAOZZA	4-2, 4
5995-01-222-4209	Cable Assembly, Special Purpose, Electrical CX-13291/VRC (3 FT, 0 IN) (A3014037-1)	1	PAOZZA	4-2, 2
5995-01-219-7025	Cable Assembly, Radio Frequency, CG-3856/VRC (5 FT, 0 IN) (A3014032-3)	1	PAOZZA	4-2, 3

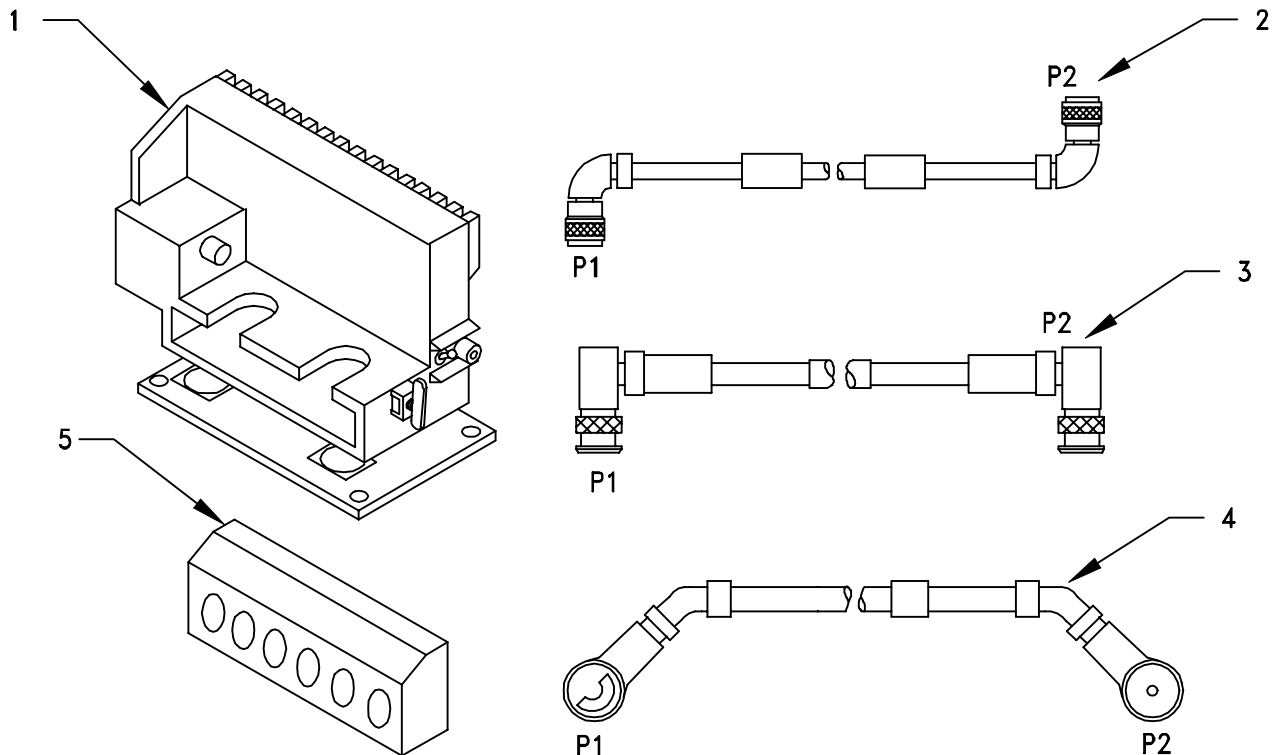

Figure 4-2. Illustrated Parts List for Table 4-2

4.3.3 Consumable Materials. The table below lists materials required for installation but not supplied with MK.

NSN	NOMENCLATURE
8040-00-117-8510	Adhesive-Sealant, Clear, RTV
6850-00-880-7616	Silicone Compound, MIL-S-8660
8030-00-292-1102	Conductive Anti-seize Compound

4.4 Tools and Test, Measurement, and Diagnostic Equipment (TMDE) Required. The following tools and TMDE are needed for installation.

NOMENCLATURE	NSN	QUANTITY
Radio Set*		1
Electric Grinder or Equivalent		1
Pocket Knife, Electrician's	5110-00-240-5943	1
Screwdriver, No. 2 Point Phillips, 4 in	5120-00-234-8913	1
Screwdriver, 1/4 in Flatblade, 4 in	5120-00-222-8852	1
Pliers, Round Nose	5120-00-240-6172	1
Pliers, Diagonal Cutting	5110-00-965-0974	1
Wrench, Open/Box: 1/2 in	5120-00-228-9506	1
Handle, Socket Wrench: 1/2 in	5120-00-240-5364	1
	5120-00-227-0977	1
Electric Drill	5130-00-889-8994	1
Drill Bit: 11/32 in	5133-00-227-9664	1

* Use radio issued with your station if available.

5. INSTALLATION PROCEDURES.

This section describes where and how to install MK items in the vehicle. See Figure 5-1 for an overall view of where vehicular and MK equipment, as well as radio components, typically will be installed. When installing MK equipment, be sure to read and follow instructions and illustrations carefully.

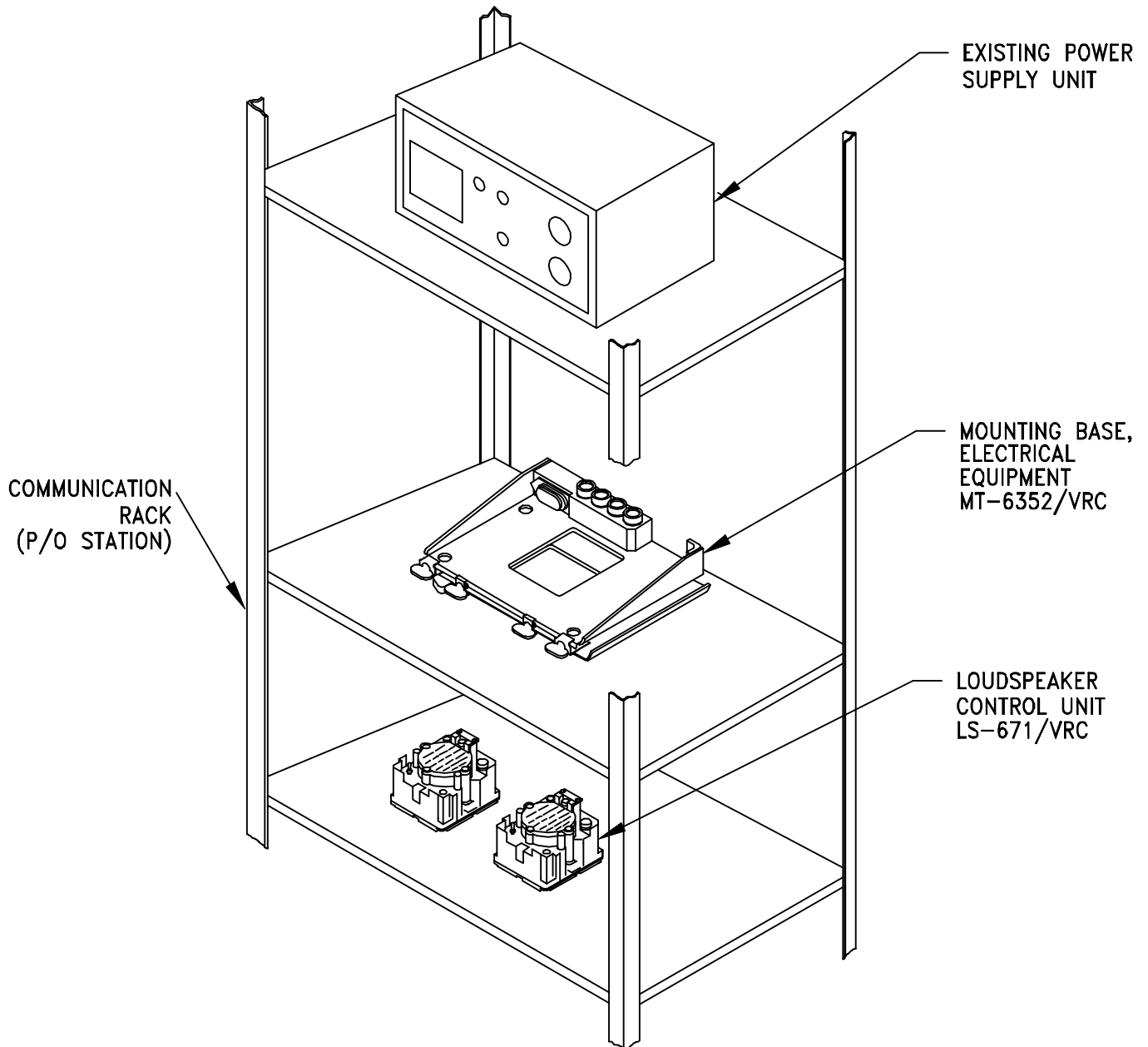

Figure 5-1 (1). MK and Radio Installation: MK Equipment Locations (Typical)

5. INSTALLATION PROCEDURES. Continued.

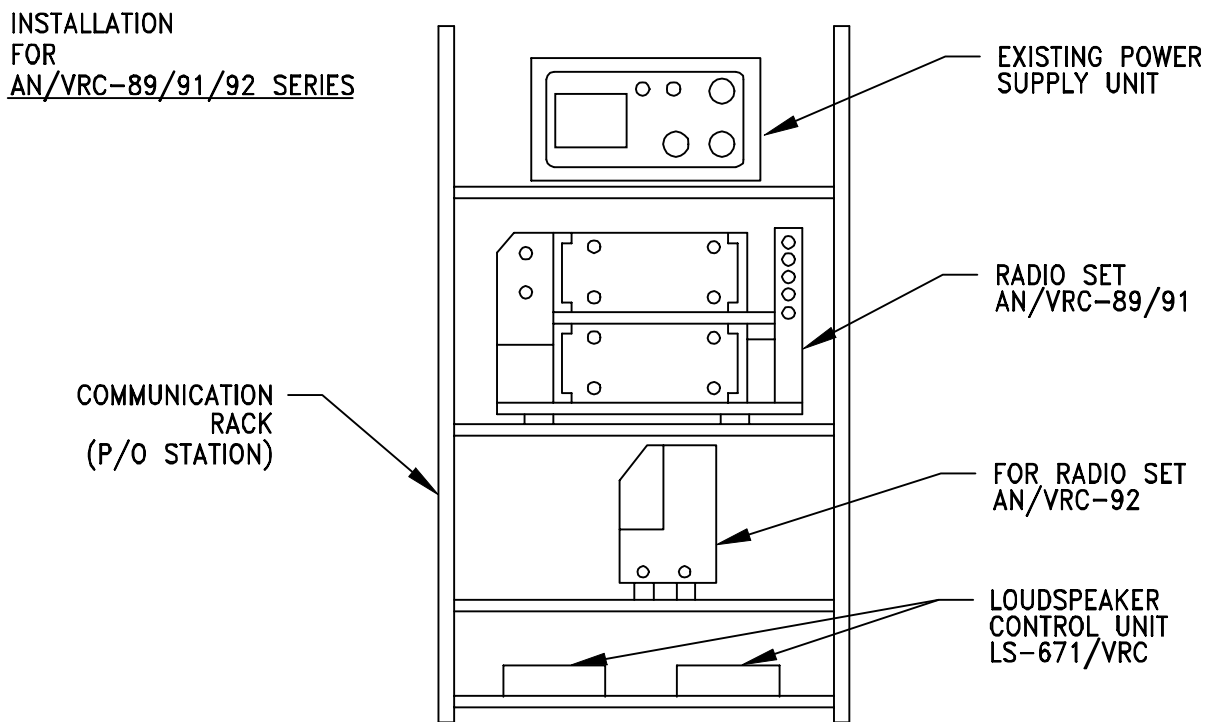
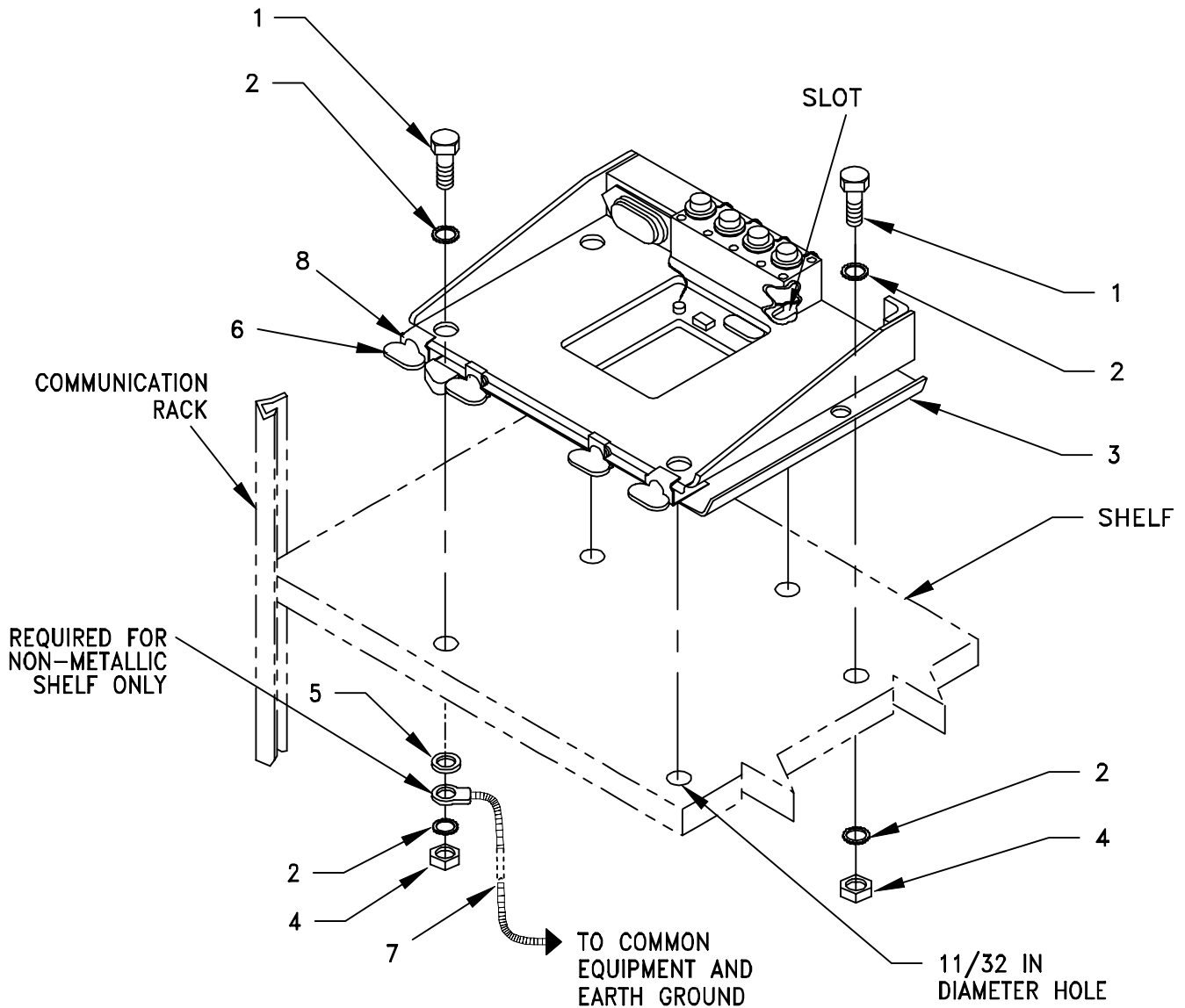

Figure 5-1 (2). MK and Radio Installation: Radio Equipment Location

5.1 Installation of Mounting Base, Electrical Equipment MT-6352/VRC (mounting base). Remove and retain attaching bag of 5/16 in mounting hardware for installation. To insure good electrical grounding, any rust, corrosion or paint around mounting holes in a metallic shelf should be removed before installing the mounting base. On a non-metallic shelf, use ground straps to insure that mounting base is attached to a common equipment and earth ground. See Figure 5-2 and perform steps a through f and step g to install mounting base on a metallic shelf and step a, c, d, e, g, and h to install mounting base on a non-metallic shelf.

ITEM	ACTION	REMARKS
NOTE		
Apply a thin coat of adhesive-sealant to both sides of each internal/external-toothed (IET) washer during installation, and to the area of contact where IET washer is to be placed. When installing mounting base to a thick shelf, use the longer machine bolts (5/16-24 x 1 1/2 in) supplied.		
a. Mounting holes for mounting base (3).	If existing, go to step b. If not existing, use mounting base as a template and drill five 11/32 in diameter holes through shelf. See Figure 5-2.	Tools: Electric drill and 11/32 in drill bit.
b. For metallic shelf: mounting base (3) and shelf.	Remove a 2" square area of paint on the underside of the mounting base (3) around left front and rear mounting holes. Remove a 2" square area of paint on the existing shelf around the mounting holes drilled in step a that mate with left front and rear mounting holes of mounting base (3). Clean the paint removed areas and apply a thin coat of conductive anti-seize compound.	Tools: Electric grinder or equivalent.
c. Mounting base (3).	Place on shelf over mounting holes. See Figure 5-2.	
d. Two outer thumbscrews (6).	Turn ccw until both sets of threads have cleared center of holes.	
e. Mounting base (3).	Align four holes and rear slot with matching hole pattern in shelf.	
f. For metallic shelf: five machine bolts (1), ten internal/external-toothed (IET) washers (2) and five nuts (4).	Install and secure to mounting base (3) and shelf.	Tools: 1/2 in socket and 1/2 in open/box wrench.
g. For non-metallic shelf: five machine bolts (1), ten internal/external-toothed (IET) washers (2), five flat washers (5), five nuts (4) and lead, electrical (7).	Install and secure to mounting base (3) and shelf.	Tools: 1/2 in socket and 1/2 in open/box wrench.
h. Two outer thumbscrews (6).	Tighten and secure to rim clenching clamps (8) and mounting base (3).	

5.1 Installation of Mounting Base, Electrical Equipment MT-6352/VRC (mounting base). Continued.



1. MACHINE BOLT (5/16-24 x 1 IN) OR MACHINE BOLT (5/16-24 x 1 1/2 IN)
2. IET WASHER (5/16 IN)
3. MOUNTING BASE
4. NUT (5/16-24 IN)
5. FLAT WASHER (5/16 IN)
6. THUMBSCREW
7. LEAD, ELECTRICAL (5 FT, 0 IN)
8. RIM CLENCHING CLAMP

Figure 5-2. Mounting Base Installation

5.2 Installation of Loudspeaker, Control-Unit, LS-671/VRC (speaker). Mounting location for speakers to be determined by the station commander.

ITEM	ACTION	REMARKS
a. Mounting holes for plate, mounting (1).	Using plate, mounting (1) as a template, drill two 11/32 in diameter holes through mounting surface. See Figure 5-3.	Tools: Electric drill and 11/32 in drill bit.
b. Plate, mounting (1)	Align bottom slots with holes drilled in step a.	
c. Two machine bolts (2), two flat washers (3), two lock washers (4) and two nuts (5).	Install and secure to plate, mounting (1) and mounting surface.	Tools: 1/2 in socket and 1/2 in open/box wrench..
d. Speaker (6).	Place on plate, mounting (1)..	
e. Two externally-relieved body screws (7).	Thread through and secure to speaker (6) and plate, mounting (1).	Tools: Flatblade screwdriver.
f. Handset.	Connect and secure to speaker (6) connector J2.	
g. Steps a through f.	Repeat to install remaining speaker.	

5.2 Installation of Loudspeaker, Control-Unit, LS-671/VRC (speaker). Continued

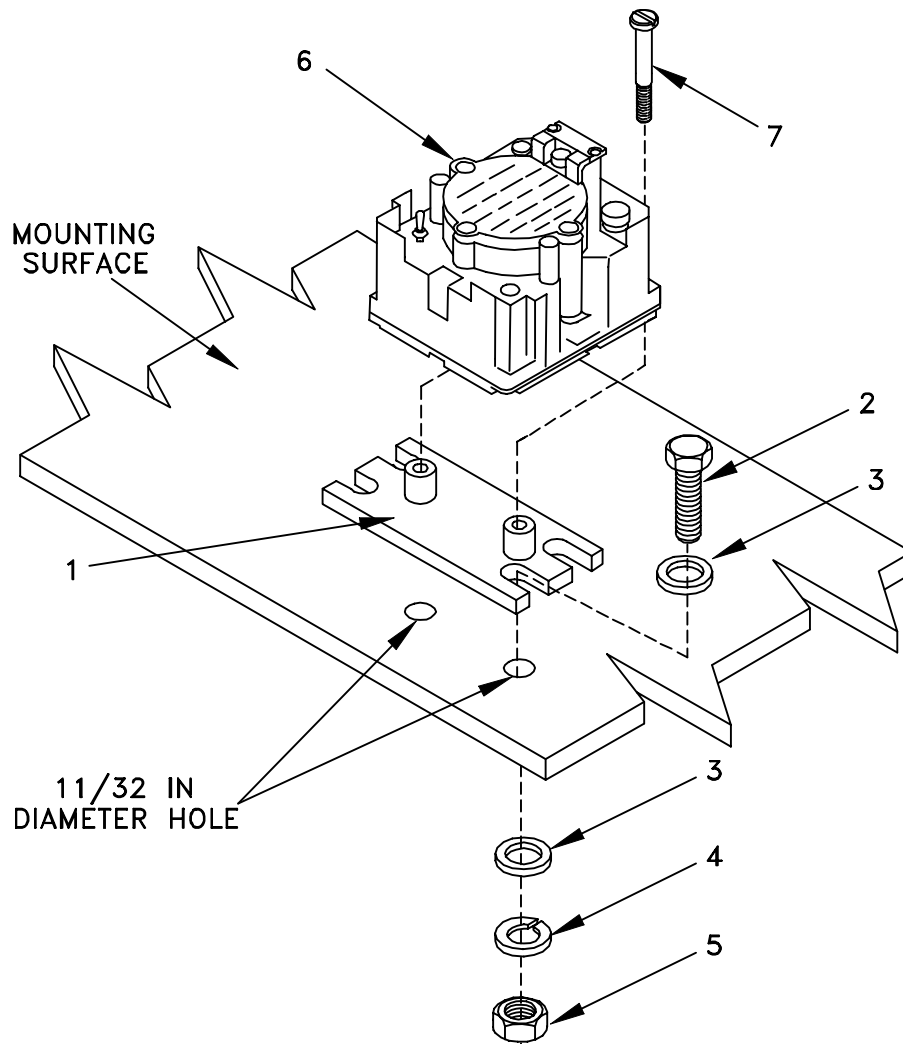

1. PLATE, MOUNTING
2. BOLT MACHINE (5/16-24 x 1 1/2 IN)
3. FLAT WASHER (5/16 IN)
4. LOCK WASHER (5/16 IN)
5. NUT (5/16 IN)
6. SPEAKER
7. BODY SCREW (P/O PLATE, MOUNTING)

Figure 5-3. Speaker Installation

5.3 Installation of Cables. To accomplish the installation, leave loop clamps and tiedown straps loose enough to adjust cable slack and allow easy adjustment of equipment. When installation is complete, tighten and secure all clamps, clips and tiedown straps.

WARNING

Make sure vehicle power source is positioned OFF or disconnected before installing cables.

ITEM	ACTION	REMARKS
a. Speaker cable (2) connector P1.	Connect and secure to speaker (3) connector J1. See Figure 5-4	
b. Speaker cable (2) connector P2.	Connect and secure to mounting base (1) connector J3.	
c. Speaker Cable (4) connector P1.	Connect and secure to speaker (5) connector J1. See Figure 5-4.	
d. Speaker cable (4) connector P2.	Connect and secure to mounting base (1) connector J3.	
e. Existing RF cable.	Position on mounting base (1).	
f. Power cable (6) connector T1 (red) and T-2 (black).	Connect and secure to existing power supply unit	
g. Power cable (6) connector P2	Connect and secure to mounting base (1) connector J1.	

5.3 Installation of Cables. Continued

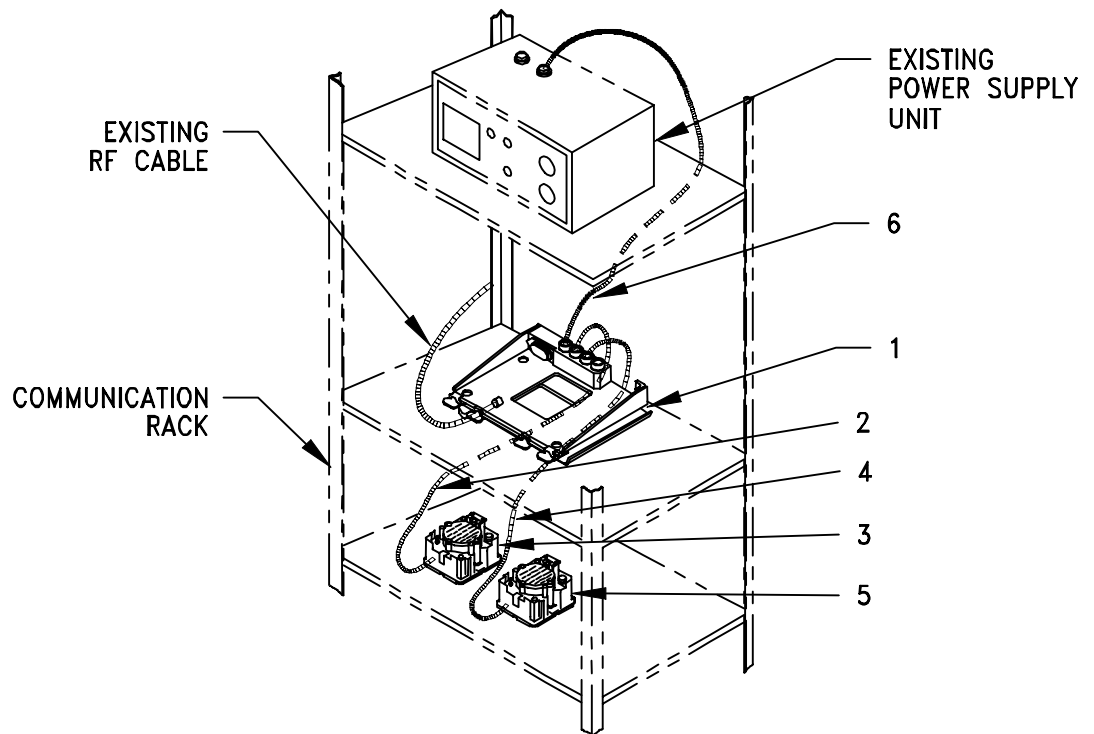

- 1. MOUNTING BASE
- 2. SPEAKER CABLE CX-13292/VRC (6 FT, 0 IN)
- 3. SPEAKER
- 4. SPEAKER CABLE CX-13292/VRC (6 FT, 0 IN)
- 5. SPEAKER
- 6. POWER CABLE CX-13302/VRC (13 FT, 0 IN)

Figure 5-4. Cable Installation: Communications Rack, Typical

5.4 Installation of Mounting Base, Electrical Equipment MT-6353/VRC. Perform steps a through e to install MT-6353/VRC mounting base on a metallic shelf and steps a, c, d, g, and h to install MT-6353/VRC mounting base on a non-metallic shelf. Refer to Section 5.5 for connection of cables.

ITEM	ACTION	REMARKS
NOTE		
<p>Apply a thin coat of adhesive-sealant to both sides of each internal/external-toothed (IET) washer during installation, and to the area of contact where IET washer is to be placed. Before proceeding, connect and secure CX-13291/VRC control cable and CX-13303/VRC power cable to MT-6353/VRC mounting base. (Refer to Section 5.7, step b.)</p>		
a. Holes for mounting base (1)	If existing, go to step b. If not existing, use mounting base (1) as a template and drill four 11/32 in diameter holes through shelf. See Figure 5-5.	Tools: Electric drill and 11/32 in drill bit.
b. For metallic shelf: mounting base (1) and shelf.	Remove a 2" square area of paint on the underside of mounting base (1) around the front two mounting holes. Remove a 2" square area of paint on the shelf around the two front mounting holes. Clean the paint removed areas and apply a thin coat of conductive anti-seize compound.	Tools: Electric grinder or equivalent.
c. MT-6353/VRC mounting base (1).	Place on shelf over mounting holes. See Figure 5-5.	
d. MT-6353/VRC mounting base (1).	Align front holes and rear slots with matching hole pattern in shelf.	
e. For metallic shelf: two machine bolts (2), two IET washers (3) and nut strip (5).	Install and secure to rear slots in MT-6353/VRC mounting base (1) and shelf.	Tools: 1/2 in socket.
f. Two machine bolts (2), two IET washers (3) and two nuts (4).	Install and secure to front holes in MT-6353/VRC mounting base (1) and shelf.	Tools: 1/2 in socket and 1/2 in open/box wrench.
g. For non-metallic shelf: two machine bolts (2), two IET washers (3), two flat washers (6) and nut strip (5).	Install and secure to rear slots in MT-6353/VRC mounting base (1) and shelf.	Tools: 1/2 in socket.
h. Two machine bolts (2), four IET washers (3), two flat washers (6), two nuts (4) and lead, electrical.	Install and secure to front holes in MT-6353/VRC mounting base (1) and shelf.	Tools: 1/2 in socket and 1/2 in open/box wrench.

5.4 Installation of Mounting Base, Electrical Equipment MT-6353/VRC. Continued.

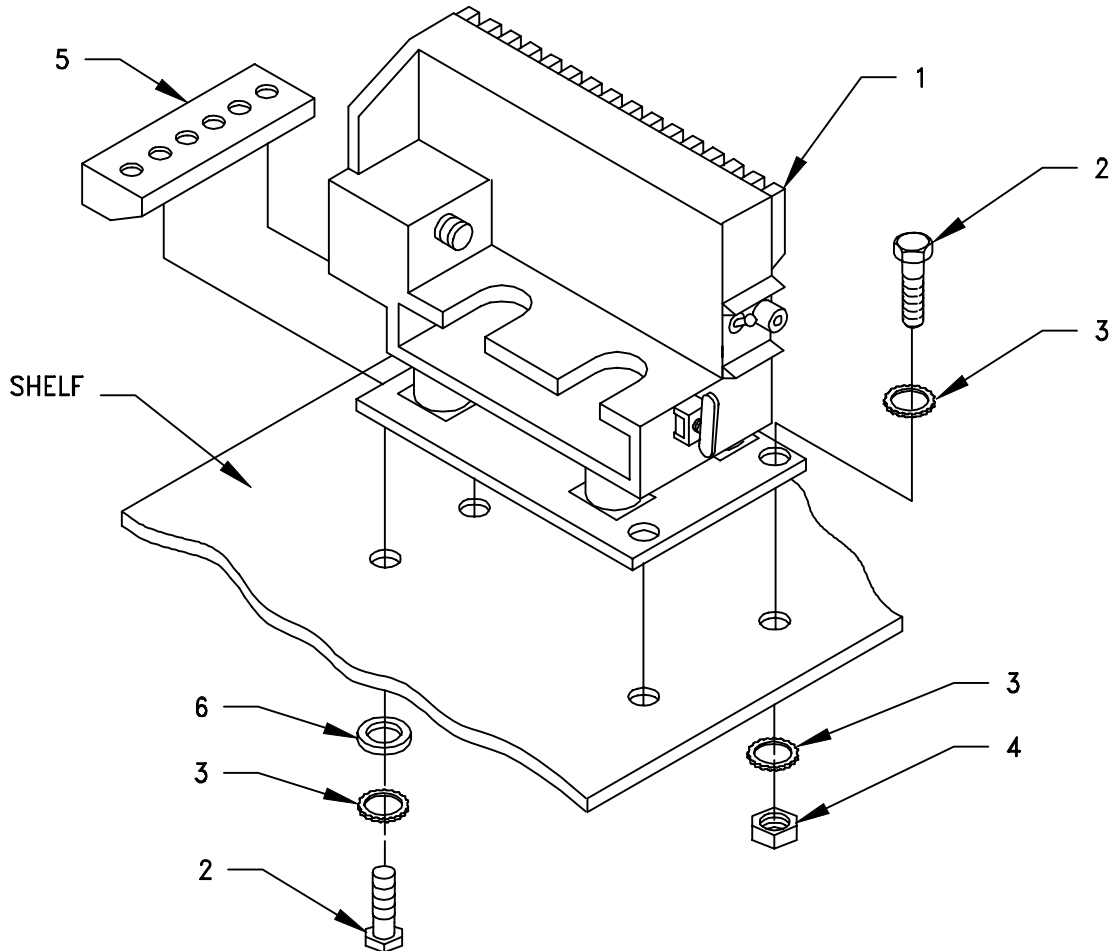

1. MOUNTING BASE
2. MACHINE BOLT (5/16-24 X 1 IN) OR
MACHINE BOLT (5/16-24 X 1 1/2 IN)
3. IET WASHER (5/16 IN)
4. NUT (5/16-24 IN)
5. NUT STRIP
6. FLAT WASHER (5/16 IN)

Figure 5-5. MT-6353/VRC Mounting Base Installation

5.5 Post-Installation and Checkout. After equipment is installed and cables are connected, perform the following steps.

ITEM	ACTION	REMARKS
a. Equipment.	Check for secure mounting. Check for loose parts, connectors, and mounting hardware.	
b. Cables.	Check for proper installation and connection of cables. See Figure 5-6 for cable connections. Unused cables should be stowed in appropriate place inside the vehicle.	
c. Loop clamps.	Check that all have been properly installed and tightened.	
d. Protective covers.	Insure that all installed cables are covered when not in use or connected.	
e. Radio issued with vehicle.	Install and connect cables. See TM 11-5820-890-20-1 or TM 11-5820-890-20-4 for installation and operational (OP) checks and instructions.	
f. MK line replaceable units.	See TM 11-5820-890-20P for Repair Parts and Special Tools List (RPSTL) information.	

5.5 Post-Installation and Checkout. Continued.

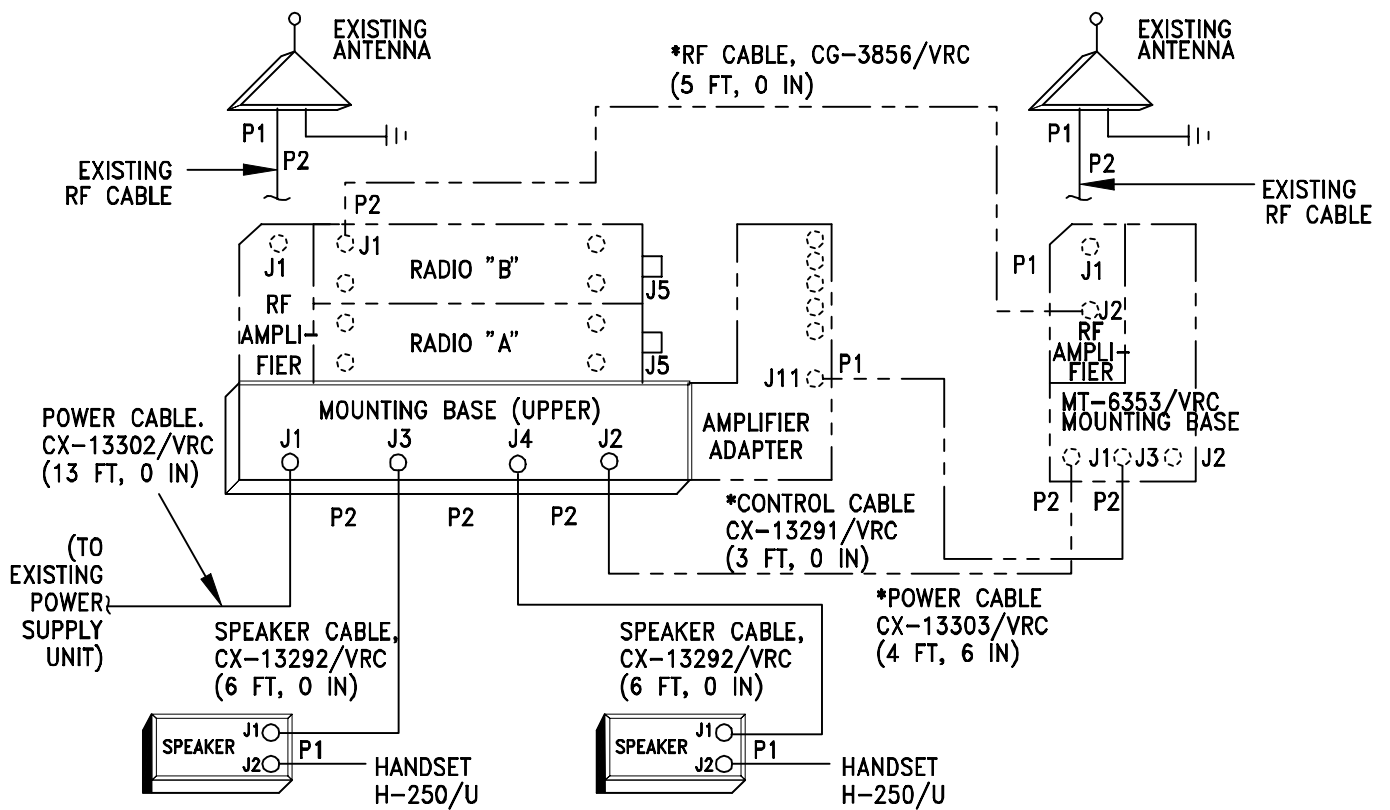

Figure 5-6. Cable Diagram: For AN/VRC-89/91/92 Series

5.5 Post-Installation and Checkout. Continued.

CABLE ASSEMBLY	FROM			TO		
	CABLE CONN.	UNIT	UNIT CONN.	CABLE CONN.	UNIT	UNIT CONN.
CX-13302/VRC (13 FT, 0 IN)	P2	Mounting base	J1	T1: Red (+) T2: Black (-)	Existing power supply unit	
CX-13292/VRC (6 FT, 0 IN)	P2	Mounting base	J3	P1	Speaker	J1
CX-13292/VRC (6 FT, 0 IN)	P2	Mounting base	J4	P1	Speaker	J1
Existing RF cable	P2	RT "B"	J1	P1	Existing antenna	
Existing RF cable	P2	RF amplifier	J1	P1	Existing antenna	
*CX-13291/VRC (3 FT, 0 IN)		Amplifier-adapter	J11	P2	MT-6353/VRC mounting base	J3
*CG-3856/VRC (5 FT, 0 IN)	P2	RT "B"	J1	P1	RF amplifier	J2
*CX-13303/VRC (4 FT, 6 IN)	P1	Mounting base	J2	P2	MT-6353/VRC mounting base	J1

* Not supplied in this MK.

Figure 5-6. Cable Diagram: For AN/VRC-89/91/92 Series. Continued

APPENDIX A

REFERENCES

AMDF	Army Master Data File (Microfiche)
AR 710-2	Supply Policy Below the Wholesale Level as Contained in Unit Supply UPDATE
AR 725-50	Requisitioning, Receipt and Issuing System in UPDATE
DA PAM 25-30	Consolidated Index of Army Publications (Microfiche)
DA PAM 710-2-1	Using Unit Supply System Manual Procedures as Contained in Unit Supply UPDATE
SB 11-131-2	Vehicular Sets and Authorized Installations, Volume II, SINCGARS and EPLRS
TM 11-5820-890-10-1	Operator's Manual (ICOM Radio Sets)
TM 11-5820-890-10-3	Operator's Manual (Non-ICOM Radio Sets)
TM 11-5820-890-20-1	Unit Maintenance Manual (ICOM Radio Sets, Vol. 1)
TM 11-5820-890-20-2	Unit Maintenance Manual (ICOM Radio Sets, Vol. 2)
TM 11-5820-890-20-3	Unit Maintenance Manual Handbook (ICOM Radio Sets)
TM 11-5820-890-20-4	Unit Maintenance Manual (Non-ICOM Radio Sets)
TM 11-5820-890-20P	Repair Parts and Special Tools List

By Order of the Secretary of the Army:

ERIC K. SHINSEKI
General, United States Army
Chief of Staff

Official:

JOEL B. HUDSON
Administrative Assistant to the
Secretary of the Army

9920213

DISTRIBUTION:

To be distributed in accordance with the initial distribution number (IDN) 369646 requirements for TB 11-5820-890-20-2.

SOMETHING WRONG WITH THIS PUBLICATION



THEN ... JOT DOWN THE INFO ABOUT IT ON THIS FORM. CAREFULLY TEAR IT OUT. FOLD IT AND DROP IT IN THE MAIL.

FROM: (PRINT YOUR UNIT'S COMPLETE ADDRESS)

Commander
Stateside Army Depot
ATTN: AMSTA-US
Stateside, NJ 07703-5007

DATE SENT

10 July 1995

PUBLICATION NUMBER

TM 11-5840-340-12

PUBLICATION DATE

23 Jan 74

PUBLICATION TITLE

Radar Set AN/PRC-76

BE EXACT PIN-POINT WHERE IT IS

IN THIS SPACE TELL WHAT IS WRONG AND WHAT SHOULD BE DONE ABOUT IT:

PAGE NO	PARA-GRAPH	FIGURE NO	TABLE NO
2-25	2-28		
3-10	3-3		3-1
5-6	5-8		
		FO-3	

Recommend that the installation antenna alignment procedure be changed throughout to specify a 20 IFF antenna lag rather than 10

REASON: Experience has shown that with only a 10 lag, the antenna servo system is too sensitive to gusting in excess of 25 knots, and has a tendency to rapidly accelerate and decelerate as it hunts, causing strain to the drive train. Hunting is minimized by adjusting the lag to 20 without degradation of operation.

Item 5, Functional column. Change 2 dB" to 3 dB".

REASON: The adjustment procedure for the TRANS POWER FAULT indicator call for a 3 dB (500 watts) adjustment to light the TRANS POWER FAULT indicator.

Add new step f.1 to read, Replace cover plate removed in step d above."

REASON: To replace the cover plate.

ZONE C 3. On J1-2, change +24 VDC" to +5 VDC".

REASON: This is the output line of the 5 VDC power supply. +24 VDC is the input voltage.

PRINTED NAME, GRADE OR TITLE AND TELEPHONE NUMBER

SSG I. M. DeSpirito 999-1779

SIGN HERE

TEAR ALONG DOTTED LINE

SOMETHING WRONG WITH THIS PUBLICATION



THEN ... JOT DOWN THE INFO ABOUT IT ON THIS FORM. CAREFULLY TEAR IT OUT. FOLD IT AND DROP IT IN THE MAIL.

DATE SENT

PUBLICATION NUMBER

PUBLICATION DATE

PUBLICATION TITLE

BE EXACT PIN-POINT WHERE IT IS

IN THIS SPACE TELL WHAT IS WRONG AND WHAT SHOULD BE DONE ABOUT IT:

PAGE NO	PARA-GRAPH	FIGURE NO	TABLE NO

TEAR ALONG DOTTED LINE

PRINTED NAME, GRADE OR TITLE AND TELEPHONE NUMBER

SIGN HERE

FILL IN YOUR
UNIT'S ADDRESS

FOLD BACK

DEPARTMENT OF THE ARMY



OFFICIAL BUSINESS

PLEASE
AFFIX
STAMP
POSTAGE
REQUIRED

TEAR ALONG DOTTED LINE

Commander
U.S. Army Communications-Electronics Command
and Fort Monmouth
ATTN: AMSEL-LC-LEO-D-CS-CFO
Fort Monmouth, New Jersey 07703-5000



FOLD BACK

